

MODEL 30



Pneumatic Impulse Sealer

General Purpose Sealers

MODEL 20



Manual Impulse Sealer

MODEL 30: Impulse Sealer

Our Pneumatic Jaw Pressure Sealer is the best all around bag sealer on the market and our top model for volume production. It combines performance with value in a machine that adjusts for most film sealing situations, even those difficult materials such as nylon, Tyvek®, Teflon®, ESD bags, and plastic films that are over 30 mils thick. The system is equipped with high quality components including an electric foot switch that allows a single operator to easily and safely activate the sealing process. The sealing cycle is automatically halted at any stage when the operator releases the foot switch. An external air supply is required.

RELIABILITY

The Model 30 can be relied on to produce a quality seal every time, even when using Mil-Spec films that demand consistent heat and pressure.

EASY PORTABILITY

The ergonomically designed Accu-Seal 30 can handle your toughest job-yet, at 26 lbs.(*) it's the lightest sealer on the market. You might need a forklift to move other sealers, but with the Accu-Seal 30, pick it up and go!

MODEL 20: Manual Impulse Sealer

This Portable Heavy Duty Bag Sealer is the machine we most often recommend when a manual, yet rugged bag sealer is needed. This portable tabletop unit can be used for low volume production as well as situations that require heavier film thickness. The Model 20 sealer can also be used with a mechanical foot pedal, offering hands-free operation for an easy, convenient way to seal.



IMPULSE SEALER

MODEL 30

PNEUMATIC JAW PRESSURE ACCU-SEALER

BUILT-IN FEATURES

- Pneumatic Jaw Pressure Control
- 10 second Adjustable Electronic Heat Timer
- 60 second Adjustable Electronic Cool timer
- Electronic Foot Switch Activator

SPECIFICATIONS

- Seal Widths: 1/4" Standard. Other seal widths and styles also available
- Seal Lengths: 15", 20", 25", 30" or 35"
- Requirements:
 - Power: 120 Vac, 7 Amps (1/4" x 20")
 - Air: 1.0 CFM @ 80 PSI
- Size:
 - Length: Seal Length +5.5"
 - Width: 9.5"
 - Height: 8.5"
- Approximate Weight: 26-40 lbs.
*15" model

FACTORY OPTIONS

- Tap to start
- Q-trim, 1/8" or Beaded Band Element

OPTIONAL ACCESSORIES

- Product Support Tray
- Portable Accu-Sealer Cart
- Ergonomic Multi-Position Accu-Seal Stand
- Industrial Air Compressor
- Ultra Quiet Lab/Office Compressor

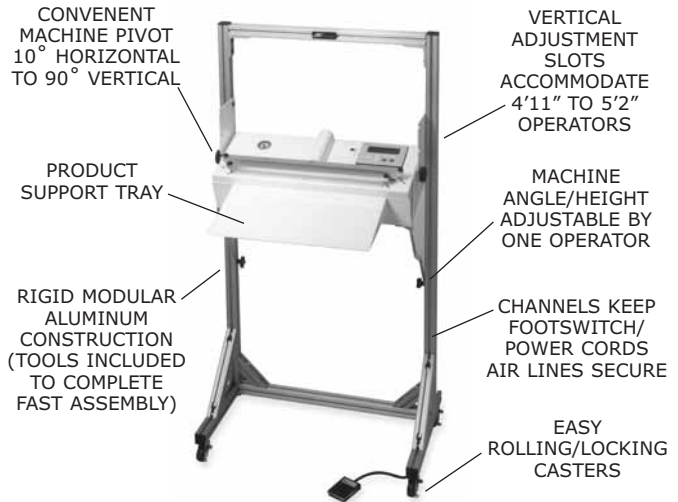

TWO-YEAR LIMITED WARRANTY

The Accu-Seal Model 20 & 30 were designed, built, and tested to give years of reliable, trouble free service.

MODEL 20

PNEUMATIC JAW PRESSURE ACCU-SEALER

BUILT-IN FEATURES

- 10 second Adjustable Electronic Heat Timer
- 60 second Adjustable Electronic Cool timer

SPECIFICATIONS

- Widths: Q-Trim/Seal, 1/8" or 1/4".
- Lengths: 15", 20", 25", 30" or 35"
- Requirements: Power - 120 Vac, 7 Amps
Air - Not required
- Size:
 - Length: Seal Length +5.5"
 - Width: 9.5"
 - Height: 8.5"
- Approximate Weight: 26-40 lbs.

OPTIONAL ACCESSORIES

- Product Support Tray
- Mechanical Foot Pedal



OPTIONAL PORTABLE ACCU-SEALER CART (SHOWN W/INDUSTRIAL COMPRESSOR)



OPTIONAL ULTRA-QUIET LAB/OFFICE COMPRESSOR



Authorized Distributor:
WEST COAST PLASTICS EQUIPMENT
800-392-8569
FAX 310-837-4947
www.sealer.net